

we:boost

Installation Guide

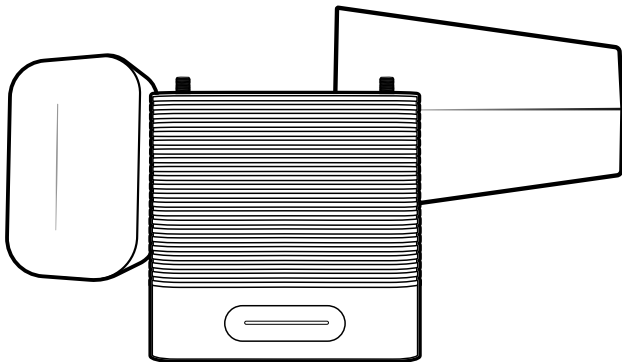

Home MultiRoom Home Cell Signal Booster Kit

Use our **weBoost App** to guide you through the installation. See inside page for more details.

Download the weBoost App

Use our app to guide you through setting up a weBoost cell phone signal booster in your home, business, or vehicle. Boost every network, including 5G, right away.



Index

Package Contents	1
Installation Overview	2
STEP 1 Inside Antenna & Booster Placement	4
STEP 2 Find Nearest Cell Tower & Mount Outside Antenna	6
STEP 3 Route Cable & Connect Outside Antenna to Booster	8
STEP 4 Route Cable & Connect Inside Antenna to Booster	9
STEP 5 Power Up the Booster & Optimize the System	10
Measuring Booster Performance & Optimizing the System	12
Booster Light Patterns	15
Troubleshooting	17
Safety Guidelines	20
Specifications	23
Warranty	24

Package Contents



Booster, Wall
Mount Bracket &
Power Supply



Outside Antenna
& Wall Mount
Bracket

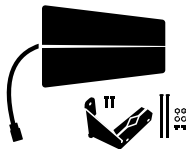

Outside Antenna &
Mounting Bracket
(w/hardware)



30' & (2x) 15'
Cables, Window
Cable, Cable Clips &
Barrel Connector

Installation Overview

Before finalizing the installation, do a **soft install and optimize the system for best coverage.**

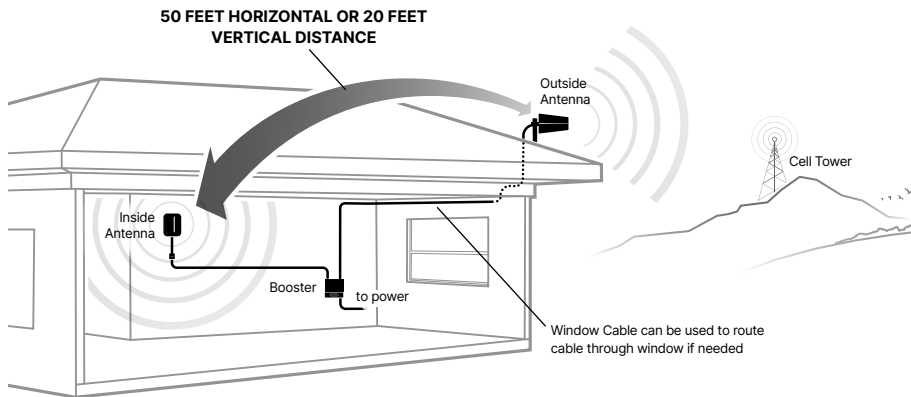

Preparation

You Will Need

Make sure the following items are ready for your installation. The tools listed below are not included in your booster kit.



1 to 2 hours



2 people (a person to help with antenna calibration)



- Ladder
- Drill (if routing cable through wall)
- 1"-3" diameter existing pole for mounting Outside Antenna (#901117 Pole Mount can be purchased separately if needed)
- Recommended: Power Strip with surge protection

STEP 1 Inside Antenna & Booster Placement

Place the **inside antenna** where you need the greatest signal boost and **place the booster** in your desired location at least **24 inches away from inside antenna**.

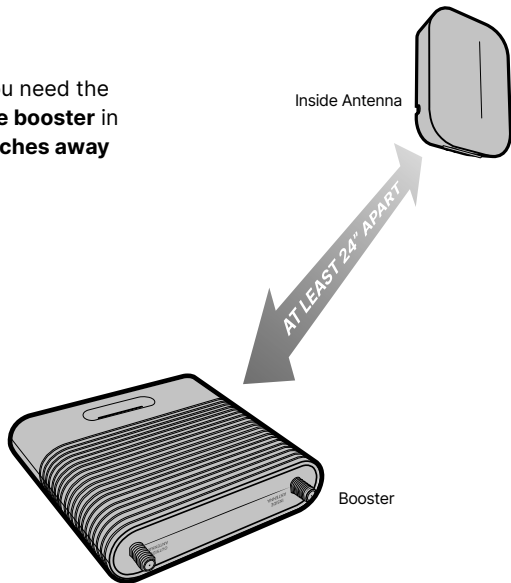

(STEP 1 cont.)

Inside Antenna Mounting Options

The inside antenna can be mounted vertical, horizontal or on a desktop. Command strips (or screws) can be used to secure mounting bracket to wall.

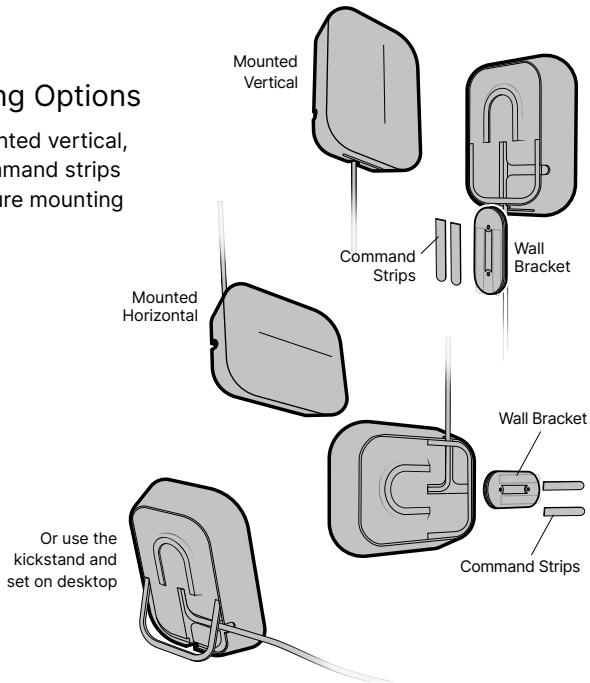

STEP 2 Find Nearest Cell Tower & Mount Outside Antenna

Find the **nearest cell tower** (this can be done by using the weBoost app) and mount the outside antenna. **Pole mounting or flat surface mounting options can be implemented.** The pole mounting option is preferred because it will be easier to adjust to the direction of the cell tower.

Attach the **mount to the outside antenna** and use the **bracket clamp** to attach the antenna to a pole or exhaust pipe.

NOTE: Mounting on existing roof exhaust pipe would be a good time-saver option. Watch out for power lines.

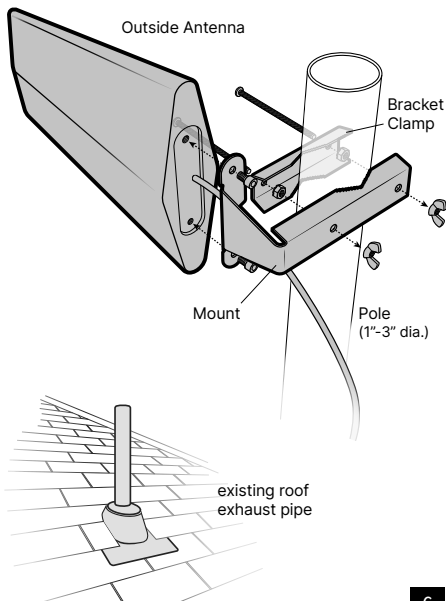

(STEP 2 cont.)

Flat Surface Mounting Option

Before implementing this option, **find the nearest cell tower** (this can be done by using the weBoost app).

If there's not a pole to easily mount the outside antenna, mounting to a flat surface such as the **fascia of your home** would be practical. Secure antenna by using only the back bracket, as shown.

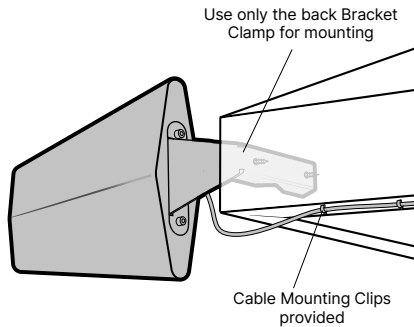

STEP 3 Route Cable & Connect Outside Antenna to Booster

Connect the 15 foot RG-6 cable to outside antenna and route cable into the home. A window entry cable is provided to help make cable entry easier if needed. All connections should be finger tightened only.

Route the other 15 foot cable to the booster and connect to the port labeled 'OUTSIDE ANTENNA'.

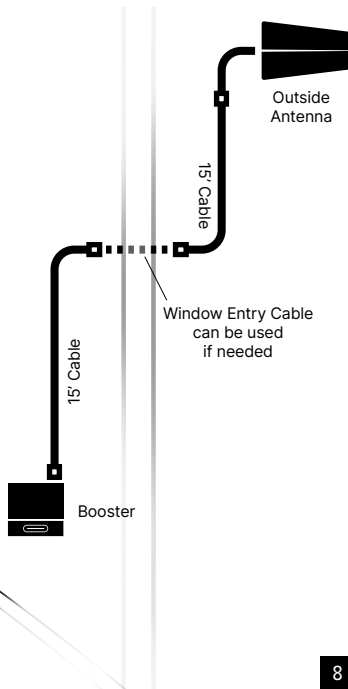
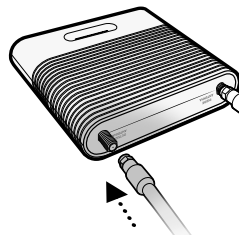

STEP 4 Route Cable & Connect Inside Antenna to Booster

Connect the 30 foot RG-6 cable to inside antenna and route to the booster and connect to the port labeled 'INSIDE ANTENNA'.

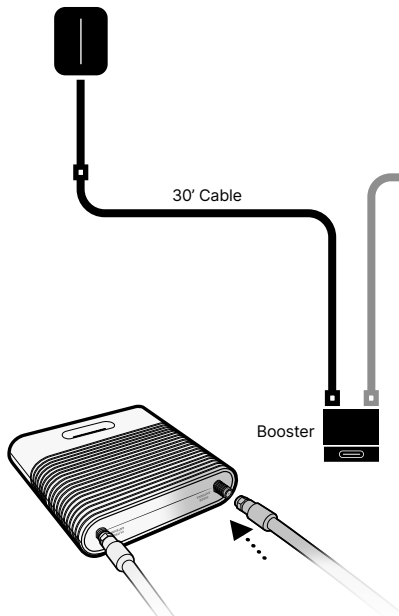

STEP 5 Power Up the Booster

Plug the **power supply** into wall outlet then connect to **end of booster labeled "  "** (turn clockwise to lock connector).

NOTE: We strongly recommend using a power strip with surge protection.

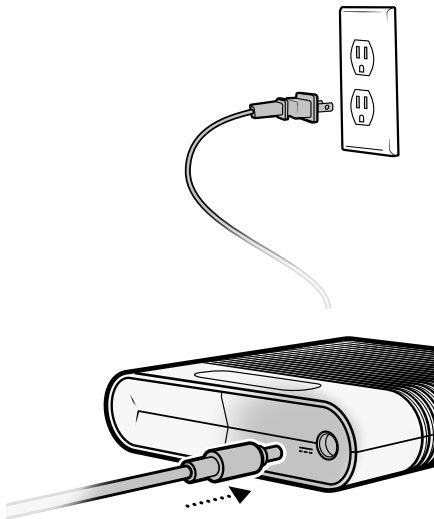

(STEP 5 cont.)

The booster can be mounted vertically with the **wall mount bracket** (included). The slide mount can be secured with command strips (included) or by screws.

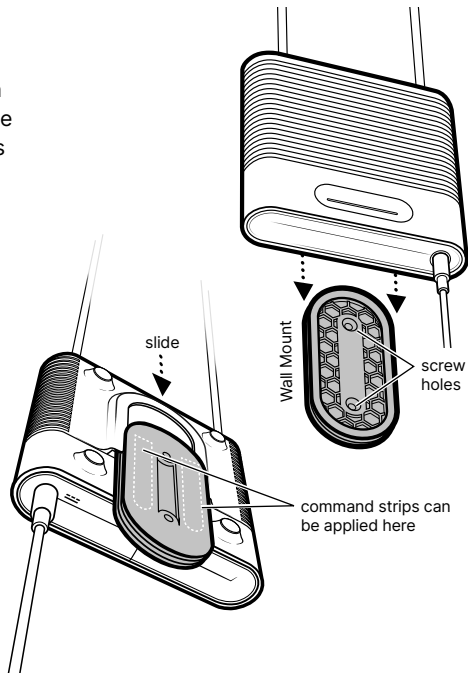

Measuring Booster Performance & Optimizing the System

We've created an easy way to learn your signal strength and compare it before and after a booster. **Download our free weBoost app** to get accurate decibel measurements to help you get the best performance from your system.



(Measuring Booster Performance & Optimizing the System cont.)

Signal Strength (dBm) with weBoost system powered **OFF**: _____
(dBm here)

Signal Strength (dBm) with weBoost system powered **ON**: _____
(dBm here)

Compare Results

Compare the decibels (dBm) on the chart below to find what signal strength you fall into.

Signal Strength	Excellent	Good	Fair	Poor	Dead Zone
3G/1x	-70dBm	-71 to -85dBm	-86 to -100dBm	-101 to -109dBm	-110dBm
4G/LTE	-90dBm	-91 to -105dBm	-106 to -110dBm	-111 to -119dBm	-120dBm

Did you know a signal increase of just 3dB is 2 times the power and signal amplification!

Gain Improvement	Signal Improvement
3dB	 2X
6dB	 4X
10dB	 10X
20dB	 100X

(Measuring Booster Performance & Optimizing the System cont.)

You can optimize your system to improve your signal strength by **rotating the outside antenna in 1/3 turn increments. After each turn, unplug and re-plug in booster's power supply**, while observing the signal level on your cell phone or in field test mode from the inside antenna's projected area.

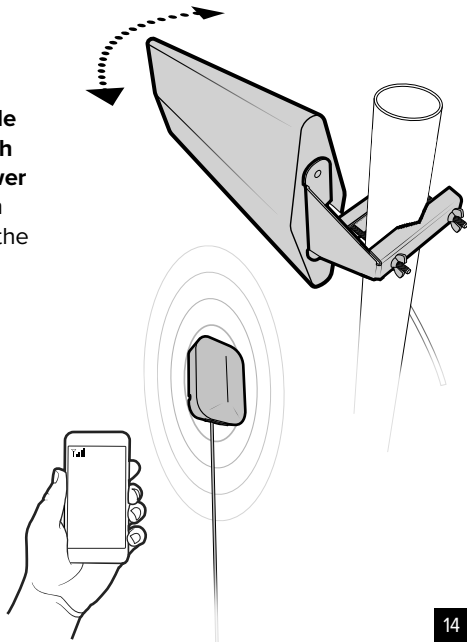

Booster Light Patterns

SOLID GREEN

This indicates that your booster is functioning properly and there are no issues with installation.

BLINKING GREEN & RED

Band has reduced gain. This indicates that one or more of the booster bands has reduced power due to a feedback loop condition called oscillation. This is a built in safety feature to prevent harmful interference with a nearby cell tower. If you are already experiencing the desired signal boost, then no further adjustments are necessary. If you are not experiencing the desired boost in coverage then refer to the Troubleshooting section.

SOLID RED

Band has shutoff. This is due to a feedback loop condition called oscillation. This is a built in safety feature that causes a band to shut off to prevent harmful interference with a nearby cell tower. Refer to Troubleshooting section.

BLINKING GREEN & YELLOW

Band has reduced gain. This indicates that one or more of the booster bands has reduced

(Booster Light Patterns cont.)

power due to overload from nearby cell tower. This is a built in safety feature to prevent harmful interference with a nearby cell tower. If you are already experiencing the desired signal boost, then no further adjustments are necessary. If you are not experiencing the desired boost in coverage then refer to the Troubleshooting section.

SOLID YELLOW

Band has shutoff due to overload from nearby cell tower. Outside Antenna must be adjusted. Refer to Troubleshooting section.

LIGHT OFF

If the Signal Booster's light is off, verify your power supply has power.

Troubleshooting

FIXING BLINKING OR RED LIGHT ISSUES

This section is only applicable if the light on the booster is red, blinking red or green /red lights.

- 1 Verify outside and inside antenna face away from each other. Un-plug and re-plug in power supply.
- 2 Verify the inside antenna is at least 24 inches from the booster and pointed away from the booster. Unplug and re-plug in power supply.
- 3 Tighten all cable connections (be sure to finger tighten only, do NOT use tools). You may want to undo and redo the connection completely. Unplug and re-plug in power supply.
- 4 Increase the distance (horizontally or vertically) between the outside and inside antenna. Add included cable if needed. Un-plug and re-plug in power supply.

If you are having any difficulties while testing or installing your booster, contact our weBoost Customer Support team for assistance (1-866-294-1660).

(Troubleshooting cont.)

FIXING BLINKING OR YELLOW LIGHT ISSUES

This section is only applicable if the light on the booster is yellow, blinking green /yellow lights.

Outside Antenna must be adjusted. Wait 10 seconds between adjustments for the lights to reset.

Pole Mount Option: Rotate the outside antenna away from the strongest cellular signal in small increments (1/3) until the light turns green. Unplug and re-plug in power supply.

Mounting On Side Of Roof Option: Change mount location. Move the outside antenna to a different location of the home/building to see if the lights turn green. Un-plug and re-plug in power supply. Then secure in place.

 1-866-294-1660

 www.weboost.com

 support@weboost.com

(Troubleshooting cont.)

FREQUENTLY ASKED QUESTIONS

How can I contact customer support?

Customer Support can be reached Monday through Friday by calling 1-866-294-1660, or through our support site at support.weboost.com.

Why do I need to create distance between the outside antenna and inside antenna?

Antennas connected to a booster create spheres of signal. When these spheres overlap, a condition called oscillation occurs. Oscillation can be thought of as noise, which causes the booster to scale down its power or shut down to prevent damage. The best way to keep these spheres of signal from overlapping is to maximize separation between the inside and outside antennas.

Safety Guidelines

To uphold compliance with network protection standards, all active cellular devices must maintain at least six feet of distance from Inside Panel and Dome Antennas and at least four feet of distance from Desktop Antenna.

Use only the Power Supply provided in this package. Use of a non-weBoost product may damage your equipment.

The signal booster unit is designed for use in an indoor, temperature-controlled environment (less than 100 degrees Fahrenheit). It is not intended for use in attics or similar locations subject to temperatures in excess of that range.

RF Safety Warning: Any antenna used with this device must be located at least 8 inches from all persons.

AWS Warning: The Outside Antenna must be installed no higher than 10 meters (31 feet 9 inches) above ground.

This is a CONSUMER device.

BEFORE USE, you **MUST REGISTER THIS DEVICE** with your wireless provider and have your provider's consent. Most wireless providers consent to the use of signal boosters. Some providers may not consent to the use of this device on their network. If you are unsure, contact your provider.

In Canada, **BEFORE USE** you must meet all requirements set out in ISED CPC-2-1-05.

You **MUST** operate this device with approved antennas and cables as specified by the manufacturer. Antennas **MUST** be installed at least 20 cm (8 inches) from (i.e., **MUST NOT** be installed within 20 cm of) any person.

You **MUST** cease operating this device immediately if requested by the FCC (or ISED in Canada) or licensed wireless service provider.

WARNING. E911 location information may not be provided or may be inaccurate for calls served by using this device.

This device may be operated **ONLY** in a fixed location for in-building use.

(Safety Guidelines cont.)

FOR MORE INFORMATION ON REGISTERING YOUR SIGNAL BOOSTER WITH YOUR WIRELESS PROVIDER IN THE U.S., PLEASE GO TO THE LINK BELOW:

<https://www.weboost.com/carrier-registration>

Antenna Info

The following accessories are certified by the FCC to be used with the Home MultiRoom Booster.

This radio transmitter 4726A-460059 has been approved by Innovation, Science and Economic Development Canada to operate with the antenna types listed below, with the maximum gain indicated. Antenna types not included in this list that have a gain greater than the maximum gain indicated for any type listed are strictly prohibited for use with this device.

	BAND 12/17	BAND 13	BAND 5	BAND 4	BAND 25/2
Outside antenna maximum permissible antenna gain (dBi) 50Ω	4.9	4.9	4.5	4.6	4.2
Inside antenna maximum permissible antenna gain (dBi) 50Ω	3.2	3.2	3.2	2.6	2.7

FIXED INSIDE ANTENNA KIT OPTIONS

Kit #	Coax Type	Ln(ft)	Antenna Type	Ω
301211	RG-6	30	Desktop	75
304419	RG-6	30	Dome	75
314440	RG-6	30	Panel	75

FIXED OUTSIDE ANTENNA KIT OPTIONS

Kit #	Coax Type	Ln(ft)	Antenna Type	Ω
314445	RG-6	30	Directional	75
314475	RG-6	30	Directional	75
304423	RG-6	30	Omni	75
304421	RG-6	30	Omni	75

Specifications

Home MultiRoom Cell Signal Booster					
Model	460059				
FCC	PWO460059				
IC	4726A-460059				
Connectors	F-Female				
Antenna Impedance	75 Ohms				
Frequency	698-716 MHz, 729-746 MHz, 746-757 MHz, 776-787 MHz, 824-849 MHz, 869-894 MHz, 1710-1755 MHz 1850-1915 MHz, 1930-1995 MHz, 2110-2155 MHz				
Power output for single cell phone (Uplink) dBm	700 MHz B12/17 21.7	700 MHz B13 21.9	800 MHz B5 23.4	2100 MHz B4 22.7	1900 MHz B25/2 21.9
Power output for single cell phone (Downlink) dBm	12.2	12.3	12.6	12.5	12.5
Noise Figure	5 dB (nominal)				
Isolation	>110 dB				
Power Requirements	4.2 VDC				

Each Signal Booster is individually tested and factory set to ensure FCC compliance. The Signal Booster cannot be adjusted without factory reprogramming or disabling the hardware. The Signal Booster will amplify, but not alter incoming and outgoing signals in order to increase coverage of authorized frequency bands only. If the Signal Booster is not in use for five minutes, it will reduce gain until a signal is detected. If a detected signal is too high in a frequency band, or if the Signal Booster detects an oscillation, the Signal Booster will automatically turn the power off on that band. For a detected oscillation the Signal Booster will automatically resume normal operation after a minimum of 1 minute. After 5 (five) such automatic restarts, any problematic bands are permanently shut off until the Signal Booster has been manually restarted by momentarily removing power from the Signal Booster. Noise power, gain, and linearity are maintained by the Signal Booster's microprocessor.

The term "IC" before the radio certification number only signifies that Industry Canada technical specifications were met. This device complies with Part 15 of FCC rules. This device contains licence-exempt transmitter(s)/receiver(s) that comply with Innovation, Science and Economic Development Canada's licence-exempt RSS(s). Operation is subject to the following two conditions: (1) This device may not cause interference, and (2) This device must accept any interference, including interference that may cause undesired operation of the device. Changes or modifications not expressly approved by weBoost could void the authority to operate this equipment.

✔ 2 YEAR WARRANTY

weBoost Signal Boosters are warranted for two (2) years against defects in workmanship and/or materials. Warranty cases may be resolved by returning the product directly to the reseller with a dated proof of purchase.

Signal Boosters may also be returned directly to the manufacturer at the consumer's expense, with a dated proof of purchase and a Returned Material Authorization (RMA) number supplied by weBoost. weBoost shall, at its option, either repair or replace the product.

This warranty does not apply to any Signal Boosters determined by weBoost to have been subjected to misuse, abuse, neglect, or mishandling that alters or damages physical or electronic properties.

Replacement products may include refurbished weBoost products that have been recertified to conform with product specifications.



RMA numbers may be obtained by contacting Customer Support.

DISCLAIMER: The information provided by weBoost is believed to be complete and accurate. However, no responsibility is assumed by weBoost for any business or personal losses arising from its use, or for any infringements of patents or other rights of third parties that may result from its use.

we:boost



3301 East Deseret Drive, St. George, UT

 1-866-294-1660  www.weboost.com  support@weboost.com

Copyright © 2019 weBoost. All rights reserved. weBoost products covered by U.S. patent(s) and pending application(s)
For patents go to: weboost.com/us/patents

NOT AFFILIATED WITH WILSON ANTENNA

GDE000320_003_10.06.23