

we:boost

Installation Guide

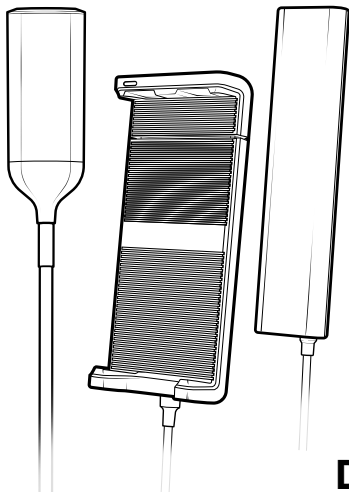

Drive Sleek OTR Vehicle Signal Booster For Trucks

Use our **weBoost App** to guide you through the installation. See inside page for more details.

Download the weBoost App

Use our app to guide you through setting up a weBoost cell phone signal booster in your home, business, or vehicle. Boost every network, including 5G, right away.



Index

Package Contents	1
Installation Overview	2
STEP 1 Select Mounting Location & Assemble the Outside Antenna	4
STEP 2 Mounting the Outside Antenna	6
STEP 3 Route Outside Antenna Cable & Connect Booster	7
STEP 4 Route Fixed Booster Cable & Connect to Cradle	8
STEP 5 Connect System to Power	9
STEP 6 Insert Your Phone Into Cradle	11
Measuring Booster Performance	12
Troubleshooting	14
Safety Guidelines	15
Specifications	18
Warranty	19

Package Contents



Sleek
Cradle



Signal Booster
& Power Supply

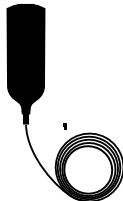

Outside
Antenna &
Cable Adapter

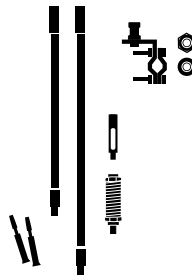

13 in. & 18 in.
Mast Extensions,
Side-Exit Adapter,
Spring, 3-Way Mount
& Thread Lock Packs



Cradle
Mount

Installation Overview

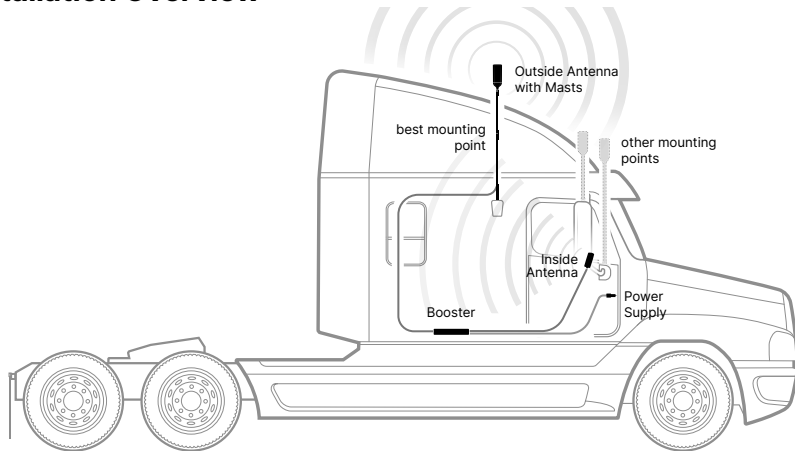

WORKS WITH DIFFERENT VEHICLE TYPES SUCH AS; SEMIS, SPRINTER VANS & PICKUPS

Depending on the type of truck, there may be built-in antenna mounting points. If the vehicle does not have built-in mounting points, the antenna includes a three-way mount that will work on vehicles with mirror rails. The antenna will also work with third party CB antenna mounts.

Best Outside Antenna Position on other Vehicle Types

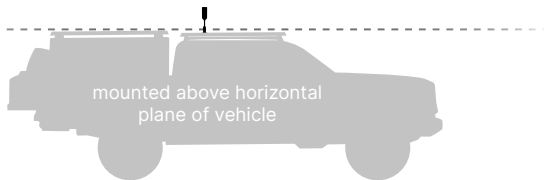

For best performance the outside antenna should be mounted above the horizontal plane of the vehicle and/or above other gear on top of the vehicle.

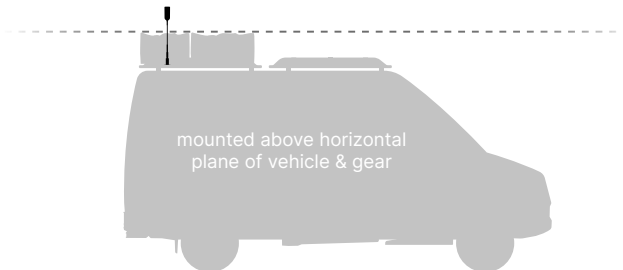

STEP 1 Select Mounting Location & Assemble the Outside Antenna

The antenna should be mounted above gear on top of the vehicle. Once you have determined the best location for the outside antenna, **insert coax cable through mast extension (mast can be used optionally), then through side-exit adapter.**

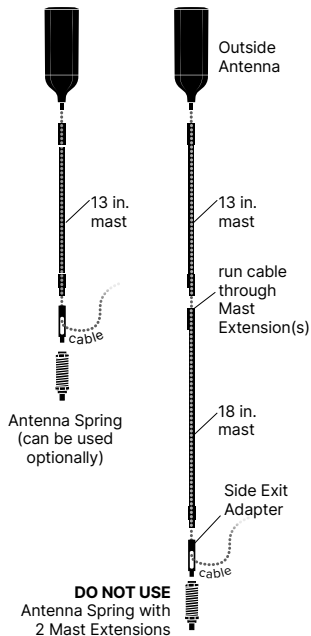
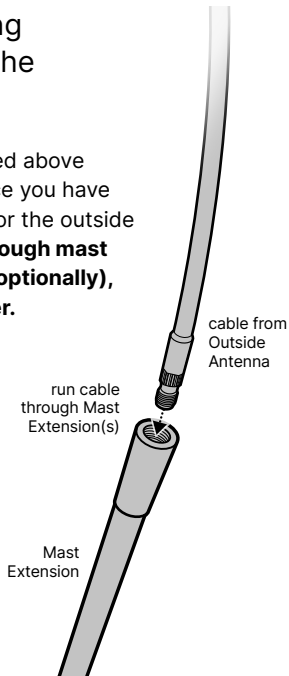

(STEP 1 cont.)

After determining outside antenna mounting location and assembly is the correct height, **apply the thread locker** precisely to thread points only (not plastic body of antenna).

Screw mast onto antenna.

Connect 14-foot cable to outside antenna cable. Heat shrink tube can be applied to the connection (optional).

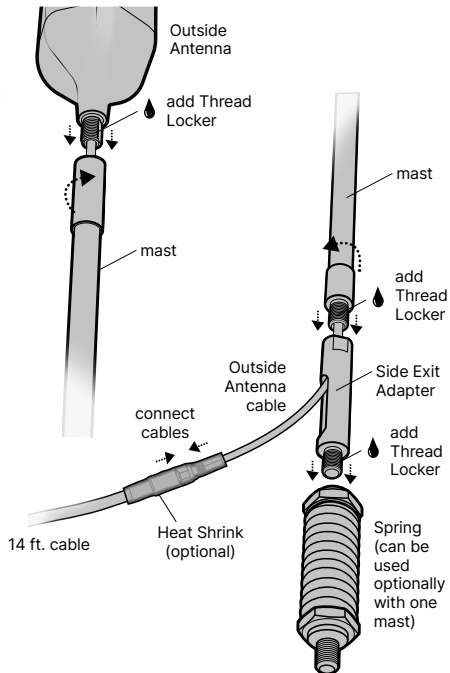

STEP 2 Mounting the Outside Antenna

If the vehicle does not have built-in mounting points, a **3-way mount** is included that will work on vehicles with mirror rails.

NOTE: The cable is strong enough that it may be shut in most vehicle doors without damaging the cable.

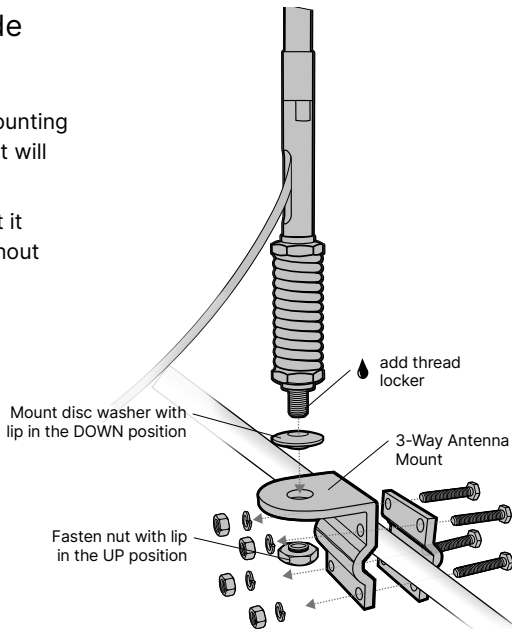

STEP 3 Route Outside Antenna Cable & Connect Booster

Connect the cable from the outside antenna to the cable adapter then to the booster port labeled **L ANTENNA** by simply pressing the connector in until you hear a “click”.

The included Velcro® can be used to mount the booster out-of-the way on the floor under a seat or mounted in the back of the cab. It is best to mount in a place where the cables cannot be tripped over or snagged (damaging the booster).

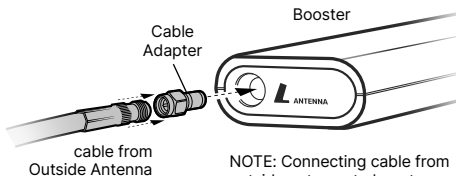

NOTE: Connecting cable from outside antenna to booster does not take much force.

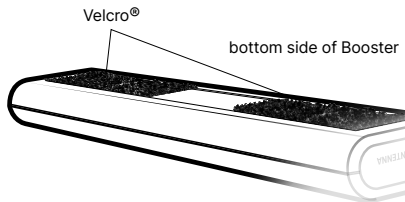

NOTE: The “hook” side of the Velcro® (already on the booster) can be used to attach to the carpet of many vehicles.

STEP 4 Route Fixed Booster Cable & Connect to Cradle

Place booster behind seats or in back area of vehicle and route the **15 foot fixed cable** to the front of the vehicle where the cradle will be located.

Connect booster cable to sleek cradle cable.

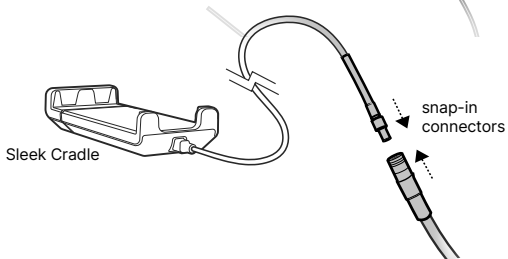
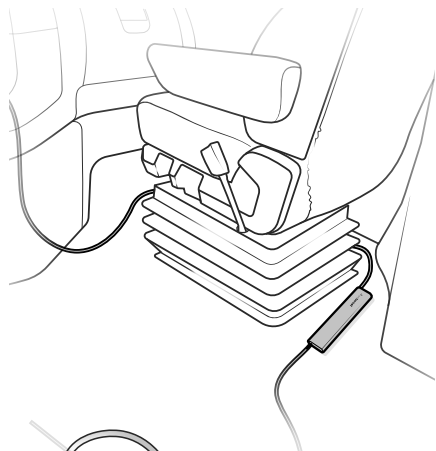

STEP 5 Connect System to Power

Connect the power to the 12V* CLA port on your vehicle and route power cable back to the booster.

NOTE: We recommend routing with the same path as the cradle/booster cable (under mats and between seats).

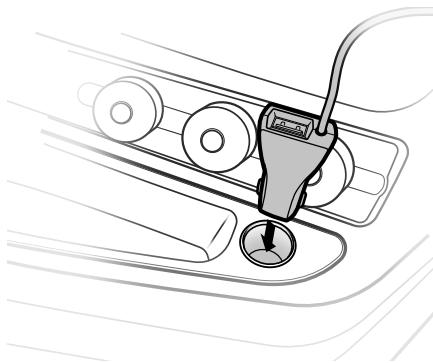

(STEP 5 cont.)

Connect power cable to booster port labeled .

NOTE: The booster will be on whenever there is power from the 12V CLA port. If your vehicle always has power going to this port, you may want to unplug this when you're not driving so the booster does not drain your battery. ***Only 12V ports are supported.**

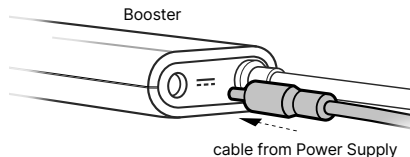
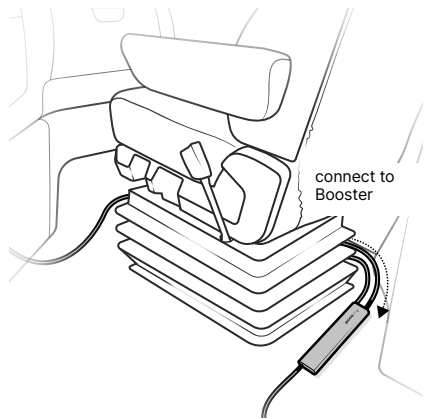

STEP 6 Insert Phone Into Cradle

Make sure you have plenty of slack in the cable going up to the cradle (Velcro® straps included to manage excess cable). Insert your phone into sleek cradle and watch your signal increase!

NOTE: A magnetic mount is provided which provides a versatile, safe and functional smartphone solution.

IMPORTANT: The FCC requires to never use the cell phone in the cradle next to your ear.

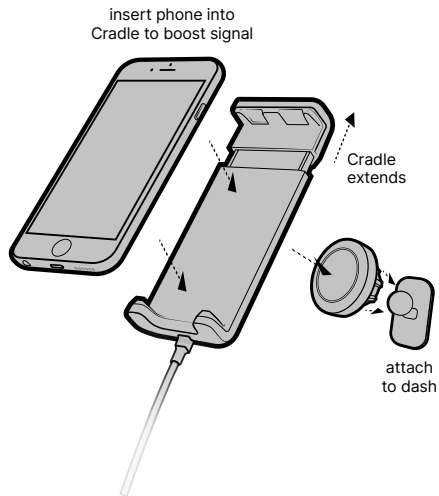

Measuring Booster Performance

We've created an easy way to learn your signal strength and compare it before and after a booster. **Download our free weBoost app** to get accurate decibel measurements to help you get the best performance from your system.



(Measuring Booster Performance cont.)

Signal Strength (dBm) with weBoost system powered **OFF**: _____
(dBm here)

Signal Strength (dBm) with weBoost system powered **ON**: _____
(dBm here)

Compare Results

Compare the decibels (dBm) on the chart below to find what signal strength you fall into.

Signal Strength	Excellent	Good	Fair	Poor	Dead Zone
3G/1x	-70dBm	-71 to -85dBm	-86 to -100dBm	-101 to -109dBm	-110dBm
4G/LTE	-90dBm	-91 to -105dBm	-106 to -110dBm	-111 to -119dBm	-120dBm

Did you know a signal increase of just 3dB is 2 times the power and signal amplification!

Gain Improvement	Signal Improvement
3dB	 2X
6dB	 4X
10dB	 10X
20dB	 100X

Troubleshooting

Solid White (LED on sleek cradle)

This indicates that your booster is functioning properly and at maximum gain.

Light Off (LED on sleek cradle)

Check/secure power connections to the CLA, booster, and cradle. If light shuts off, remove from vehicle port and plug back in to reset the system. For any questions or assistance contact our weBoost Customer Support Team (**1-866-294-1660**).

Dropped Calls

If you are regularly experiencing dropped calls in the same areas, turn off **VoLTE/HD Voice** in your phone's settings.

 1-866-294-1660

 www.weboost.com

 support@weboost.com

Safety Guidelines

Use only the Power Supply provided in this package. Use of a non-weBoost product may damage your equipment.

FCC requires to never use the cell phone in the cradle next to your ear.

RF Safety Warning: Any antenna used with this device must be located at least 8 inches from all persons.

This is a CONSUMER device.

BEFORE USE, you **MUST REGISTER THIS DEVICE** with your wireless provider and have your provider's consent. Most wireless providers consent to the use of signal boosters. Some providers may not consent to the use of this device on their network. If you are unsure, contact your provider.

In Canada, **BEFORE USE** you must meet all requirements set out in ISED CPC-2-1-05.

You **MUST** operate this device with approved antennas and cables as specified by the manufacturer. Antennas **MUST** be installed at least 20 cm (8 inches) from (i.e., **MUST NOT** be installed within 20 cm of) any person.

You **MUST** cease operating this device immediately if requested by the FCC (or ISED in Canada) or licensed wireless service provider.

WARNING. E911 location information may not be provided or may be inaccurate for calls served by using this device.

(Safety Guidelines cont.)

FOR MORE INFORMATION ON REGISTERING YOUR SIGNAL BOOSTER WITH YOUR WIRELESS PROVIDER IN THE U.S., PLEASE GO TO THE LINK BELOW:

<https://www.weboost.com/carrier-registration>

Antenna Info

The following accessories are certified by the FCC to be used with the Drive Sleek OTR.

This radio transmitter 4726A-460035 has been approved by Innovation, Science and Economic Development Canada to operate with the antenna types listed below, with the maximum gain indicated. Antenna types not included in this list that have a gain greater than the maximum gain indicated for any type listed are strictly prohibited for use with this device.

	BAND 12/17	BAND 13	BAND 5	BAND 4	BAND 25/2
Outside antenna maximum permissible antenna gain (dBi) 50Ω	2.9	1.2	2.5	2.8	6.1
Inside antenna maximum permissible antenna gain (dBi) 50Ω	2.1	2.6	3.2	2.1	2.7

FIXED INSIDE ANTENNA KIT OPTIONS

Kit #	Coax Type	Ln(ft)	Antenna Type	Ω
311251	RG-174	4	Cradle Antenna	50

FIXED OUTSIDE ANTENNA KIT OPTIONS

Kit #	Coax Type	Ln(ft)	Antenna Type	Ω
311215	LMR-100	10	Mini-Mag SMB	50
311229	RG-58	15	4G Trucker	50
311230	RG-6	25	4G RV OTR	75
314405	RG-58	14	4G NMO	50

Specifications

Drive Sleek					
Model	460035				
FCC	PWO460035				
IC	4726A-460035				
Frequency	698-716 MHz, 729-756 MHz, 777-787 MHz, 824-894 MHz, 1850-1995 MHz, 1710-1755/2110-2155 MHz				
Power output for single cell phone (Uplink) dBm	700 MHz B12/17 18.74	700 MHz B13 21.57	800 MHz B5 22.65	1700 MHz B4 25.56	1900 MHz B2 19.19
Power output for single cell phone (Downlink) dBm	2.1	2.1	-2.5	2100 MHz B4 -0.6	2.5
Noise Figure	5 dB (nominal)				
Power Requirements	12 V 1.5 A / USB 5V 2.1 A				

Each Signal Booster is individually tested and factory set to ensure FCC compliance. The Signal Booster cannot be adjusted without factory reprogramming or disabling the hardware. The Signal Booster will amplify, but not alter incoming and outgoing signals in order to increase coverage of authorized frequency bands only. If the Signal Booster is not in use for five minutes, it will reduce gain until a signal is detected. If a detected signal is too high in a frequency band, or if the Signal Booster detects an oscillation, the Signal Booster will automatically turn the power off on that band. For a detected oscillation the Signal Booster will automatically resume normal operation after a minimum of 1 minute. After 5 (five) such automatic restarts, any problematic bands are permanently shut off until the Signal Booster has been manually restarted by momentarily removing power from the Signal Booster. Noise power, gain, and linearity are maintained by the Signal Booster's microprocessor.

The term "IC" before the radio certification number only signifies that Industry Canada technical specifications were met. This device complies with Part 15 of FCC rules. This device contains licence-exempt transmitter(s)/receiver(s) that comply with Innovation, Science and Economic Development Canada's licence-exempt RSS(s). Operation is subject to the following two conditions: (1) This device may not cause interference, and (2) This device must accept any interference, including interference that may cause undesired operation of the device. Changes or modifications not expressly approved by weBoost could void the authority to operate this equipment.

✔ 2 YEAR WARRANTY

weBoost Signal Boosters are warranted for two (2) years against defects in workmanship and/or materials. Warranty cases may be resolved by returning the product directly to the reseller with a dated proof of purchase.

Signal Boosters may also be returned directly to the manufacturer at the consumer's expense, with a dated proof of purchase and a Returned Material Authorization (RMA) number supplied by weBoost. weBoost shall, at its option, either repair or replace the product.

This warranty does not apply to any Signal Boosters determined by weBoost to have been subjected to misuse, abuse, neglect, or mishandling that alters or damages physical or electronic properties.

Replacement products may include refurbished weBoost products that have been recertified to conform with product specifications.



RMA numbers may be obtained by contacting Customer Support.

DISCLAIMER: The information provided by weBoost is believed to be complete and accurate. However, no responsibility is assumed by weBoost for any business or personal losses arising from its use, or for any infringements of patents or other rights of third parties that may result from its use.

we:boost



3301 East Deseret Drive, St. George, UT

 1-866-294-1660  www.weboost.com  support@weboost.com

Copyright © 2017 weBoost. All rights reserved. weBoost products covered by U.S. patent(s) and pending application(s)
For patents go to: weboost.com/us/patents

NOT AFFILIATED WITH WILSON ANTENNA

GDE000583_001.02.27.24